



INTERNATIONAL RADIO CORP

13620 Tyee Road Umpqua, OR 97486

(541) 459-5623 fax (541) 459 5632 E-mail: inrad@rosenet.net www.qth.com/INRAD

OMNI VI AND VI+ ROOFING FILTER INSTALLATION INSTRUCTIONS.

The Ten Tec Omni VI radios have one of the better receivers in today's selection of amateur transceivers. Now these fine radios can be brought up to date with International Radios roofing filter modification. The improvements in close-in dynamic range and blocking dynamic range moves the Omni VI radios to the top of the class regardless of price. In today's crowded bands a roofing filter is necessary to compete with the modern transceivers.

This unit is programmable by a DIP switch to allow operation with or without optional filters installed in the N1 and N2 sockets. Activation of the roofing filter can be from either N1 or N2 or both. Either an SSB or a CW filter may be installed on the board. International radio has four pole filters available for this purpose. These filters have low insertion loss and do not change the noise floor of the radio. Installation is quite simple and requires soldering only two wires, +voltage and ground.

With a bit more effort, the roofing filter can be installed in an Omni V.

Detailed Instructions

Notes: 1. These instructions apply to all radio versions unless noted with an asterisk. *

2. There are two versions of the Inrad pc board. The schematics are identical. The position of J3 and J4 are reversed on the board. This does not alter the instructions, just the board appearance.

1. Remove the top and bottom covers of the radio.
2. Turn the radio bottom side up and remove the shield plate covering the circuitry.
3. Locate the amplifier shield can at the back of the radio near the antenna jack.
This is the mounting place for the roofing filter mod. See figure 1.
4. Insert the mounting posts into holes MT1 and MT2 on the mod board. The flat mounting pads should be on the solder side opposite the components.
5. Remove the paper from the posts to expose the adhesive.
6. Align the mod board over the amplifier shield can against the back wall of the radio. The two adjustments should be visible through the holes in the mod board. See figure 1. Press the board down to fasten the adhesive in place.

7. Strip and tin one end of the red and black wires supplied. Insert them into the terminal board, J5. Red goes to the screw nearest the filter and black to the screw nearest J4.
8. Loosely twist the wires together and feed them along the edge of the chassis near the IF board and to the corner of the RF board near connector "25". See figure 2.
9. Remove the corner RF board screw and install the solder lug under it.
10. Trim the black wire to length and solder to the lug.
11. On the RF board locate the 1K resistor, R55, near connector "25" and solder the red wire to the end of the resistor nearest "25". See figure 2.
 - * Omni V: The resistor is R60.
12. Remove the short coax cable marked "25" that goes between the RF and the 9 MHz IF boards.
 - * Omni V: The supplied cables will not plug into the Omni V board connectors. It is suggested that the OEM cable be cut in two and spliced on the ends of the supplied cables. Use the smaller supplied shrink wrap to cover the center conductor first and then the larger to cover the shield.
13. Insert one of the supplied coax jumpers into the 9 MHz IF board connector "25". Plug the other end into the roofing filter board jack, J2.
14. Insert the other supplied coax jumper into the RF board connector "25". Plug the other end into the roofing filter board jack, J1.
15. Remove the cable tie on the edge of the chassis near the 9 MHz IF board connector "29".
16. Remove the double stick tape covering this cable near the antenna connector. Dress the two added coax cables and the red/black wires along the chassis wall. Do not allow the coax to touch the antenna jack.
 - * Some versions may not have the double stick tape.
17. Using the supplied cable tie, fasten the cable bundle to the chassis wall and include the added wires and coax cables. Re-apply the double stick tape over the cable where it passes out of the 9 MHz IF compartment.

NOTE: The Roofing filter can be hard wired to stay in line at all times. A wire can be tacked onto the anode of D3 (end towards J2) and brought over to the ground on the terminal board, J5. If this is done, skip down to "Programming S1".

18. On the 9 MHz IF board remove the 2 pin connector "16". The other end of this cable is labeled "34" and is plugged into the small board 81620.SMD mounted on the center wall in the top of the radio.
 - *Omni V and VI and upgrades: This connector and cable are labeled "34"
19. Gently pull the connector through the large hole, away from the 9 MHz IF board. This cable may be lengthened to make it fit easily.
20. Cut one lead of the "16" cable about 2" from the connector. Solder a 4" piece of white wire to the connector end to extend the wire. Slide 2 pieces of shrink tubing on this wire. Solder the other end of the extension wire to the original cut wire. Install the two heat shrink pieces over the two solder joints.
21. Repeat for the remaining wire in the cable.
22. Feed the lengthened cable through the large hole under the fuse to the Inrad mod board. Plug the end into J3.

23. Connect the supplied 2 pin cable to the 9 MHz IF board connector "16". Route the cable through the large hole near the power fuse and plug it into the roofing filter board jack, J4.
24. This completes the installation.

Programming S1

The roofing filter mod can be set to activate the roofing filter with either the N1 or N2 or both switches on the front panel. It can do this whether there actually are filters in the N1 and N2 slots or not.

*The Omni V and some early versions of the VI have only one NARROW switch.

The functions of the four switches on S1 are as follows:

- S1-1 Activates the OEM N1 slot when on.
- S1-2 Activates the OEM N2 slot when on.
- S1-3 Activates the roofing filter with N1 when on.
- S1-4 Activates the roofing filter with N2 when on.

So, suppose you have an SSB filter in the OEM slot N1 and a CW filter in the OEM slot N2 and you have chosen a CW roofing filter. The settings should be:

S1-1 ON
S1-2 ON
S1-3 OFF
S1-4 ON

Or suppose you have no filter in OEM slot N1 and an SSB filter in OEM slot N2 and you have chosen an SSB roofing filter. The settings should be:

S1-1 OFF
S1-2 ON
S1-3 OFF
S1-4 ON

In this case, N1 will not function and N2 will activate the roofing filter and the OEM slot N2.

Parts List

- | | |
|---------------------------------------|--------------------------------------|
| 1 Roofing filter mod board | 1 red wire, 15" long |
| 1 Filter of choice | 1 black wire, 15" long |
| 2 coax jumper 8" long | 1 solder lug |
| 1 2 pin jumper cable 8" long | 3 tie wraps |
| 6 pcs shrink wrap tubing, 3/32 x 1/2" | 1 piece of solid white wire 12" long |
| 2 pcs shrink wrap tubing, 1/8 x 3/4" | 2 mounting posts |

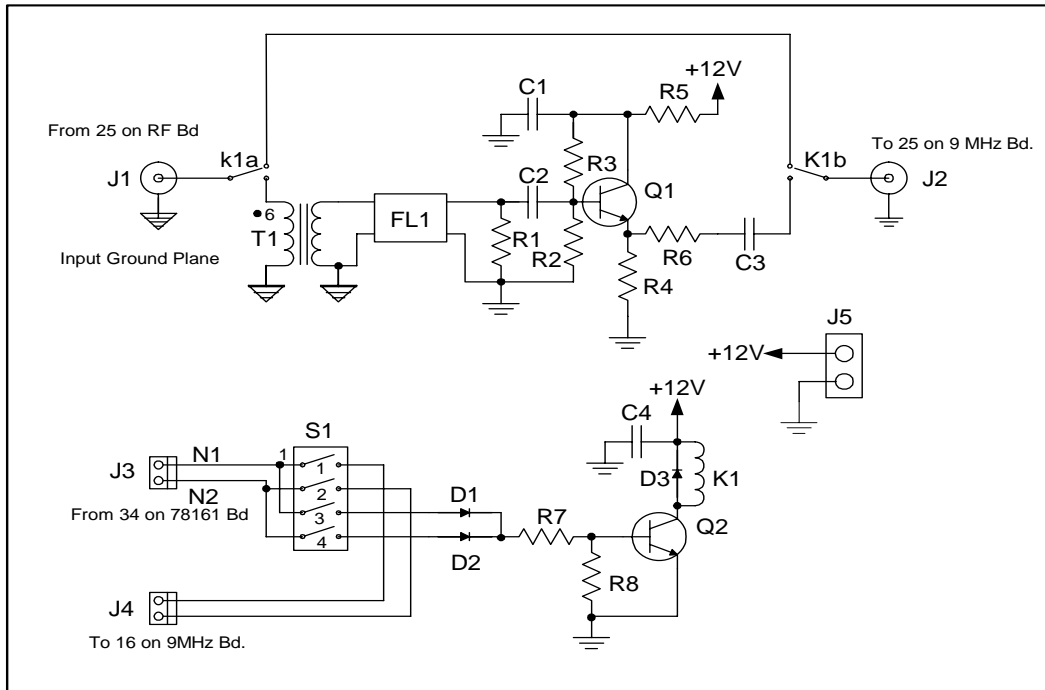

C1,2,3,4	0.1uF
D1,2,3	IN4148
FL1	Crystal filter
J1,2	Coax connector Taiko Denki TMP-JO1X-A2
J2,3	2 Pin Amp MTA 100
K1	DPDT Relay NAIS TO2-12
Q1,2	2N3904
R1	200 Ohms, 1/4 W
R2,3	10K, 1/4 W
R4	120 Ohms, 1/4 W
R5	62 Ohms, 1/4 W
R6	18 Ohms, 1/4 W
R7,8	4.7K, 1/4 W
S1	4xSPST Dip switch
T1	Transformer, 4:1



FIGURE 1

FIGURE 2

