



DX Doubler™ Two Radio Controller

Quick Start

1. Connect a source of 12 Vdc to the DX Doubler (DXD) power connector with the provided 5.5/2.5 mm OD/ID coaxial plug.
2. Connect the inputs and outputs. This could be as a minimum:
 - Audio outputs from your two radios
 - Key line to your two radios
 - Headphones
 - Keyer output
3. Select the desired mode of operation. With a minimum configuration, you would want to be in Manual mode on both Audio and Transmit sections.

You're in business! The above described simple configuration will work fine in Manual Mode. Obviously, there is much, much more capability in the DXD than reflected above in the brief Quick Start section. In the following sections, we'll go into detail on the full feature set, and how to implement them.

Contacting Top Ten

You may write to us at the following address:

Top Ten Devices, Inc.
143 Camp Council Road
Phoenixville, PA 19460

A telephone answering machine/FAX may be found at (610) 935-2684.

We are also available on the Internet. With the proliferation of Internet Services Providers, e-mail addresses may be changed frequently. As of May, 2008, the following were in effect:

N3RD: n3rd@arrl.net
W2VJN: w2vjn@arrl.net

Check our latest magazine ads for current e-mail addresses.



DX Doubler – Two Radio Controller Instruction Manual

Overview

Many operators have chosen to install a second radio (maybe just a receiver, but typically a transceiver) in their station. Normally, this would require a second set of “operator interfaces,” such as headphones, mike, keyer, footswitch, etc. Although this approach has worked in the past, it is far from optimal. The DXD provides a simple solution: A single set of operator interfaces is switched, either manually or automatically, between the two transceivers.

Features

- A single enclosure handles all switching in both Manual and Automatic mode for the following inputs and outputs:

Inputs

Radio 1 and 2 Audio (Main and Sub)
 Microphone
 CW keyer
 Footswitch
 R1 and R2 “Gnd on TX” lines

Outputs

Headphones
 Microphone audio out to Radios 1 and 2
 CW keyer output to Radios 1 and 2
 PTT line output to Radios 1 and 2

- No programming required. Hook up the inputs and outputs you want, and operate immediately.
- High RFI immunity due to lack of microprocessors and analog amplifiers.
- Interfaces to N1MM, WinTest, CT, NA, TRLog, WriteLog and other software logging programs for automatic Single Op 2 Radio (SO2R) operations.
- Supports four audio streams: Main and Sub from both Radio 1 and Radio 2.
- Mix control to vary the blend of right and left headphone audio.
- Accepts keyer paddle for use with computer CW keyer.
- Red and green LEDs graphically display which radio is active for receive and transmit.
- Auxiliary outputs available for special setups.
- CT’s “early PTT” implemented to avoid key clicks.
- Passes through Kenwood transceiver band data on the LPT port to a Top Ten Devices band decoder.

IMPORTANT NOTE:

In March, 2008 Piexx introduced their “SO2Rxlat” device, which allows the DXD to be used with a USB-only computer. More information is available at the Top Ten Devices web site.

Front Panel Controls and Indicators

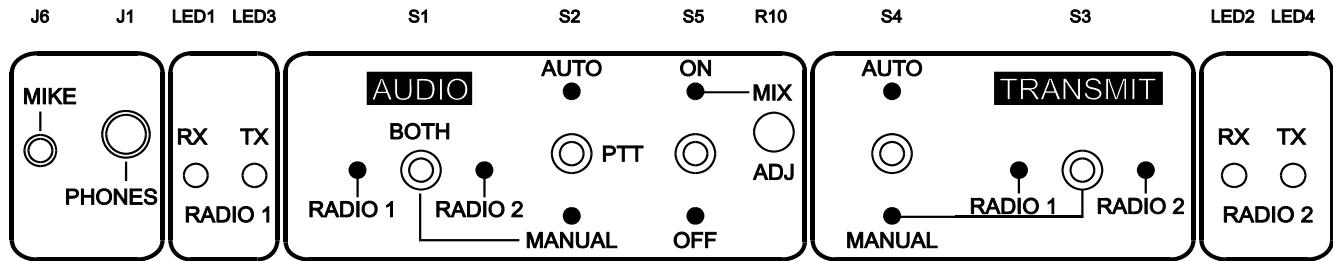

Receiver Audio Control

- S2** Receiver Audio Control Mode
- Auto – Headphones follow the radio selected by the computer
 - PTT – Allows listening to second radio while first radio is transmitting
 - Manual – Provides full manual control of headphone audio
- S1** Manual Audio Selection Control
- Radio 1 – Audio from Radio 1 in the headphones
 - Both – Radio 1 in left ear, Radio 2 in right ear
 - Radio 2 – Audio from Radio 2 in the headphones
- S5** Audio Mix On/Off
- R10** Audio Mix Adjustment – Mixes into each ear some of the other ear's audio.

Transmitter Selection

- S4** Transmitter Selection Control Mode
- Auto – Transmitter is selected by the computer
 - Manual – Transmitter is selected manually
- S3** Manual Transmitter Selection Control
- Radio 1 – Radio 1 is selected
 - Radio 2 – Radio 2 is selected

Visual Feedback

Green LEDs (RX) indicate the headphone audio source. Red LEDs (TX) indicate the active transmitter. Note that both RX LEDs can be lit, but only one TX LED can be lit, which makes sense. Radio 1 should be placed to the left of the DXD, and Radio 2 on the right. The visual feedback will tell the operator at a glance which radio is currently the source of audio, and which radio is selected as the active transmitter.

Headphone and Mike Jacks

A jack is provided for standard stereo headphones. A 3.5mm jack (approximately 1/8") is provided for mike connection. A Heil Proset will connect directly to these jacks.

Rear Panel Connections

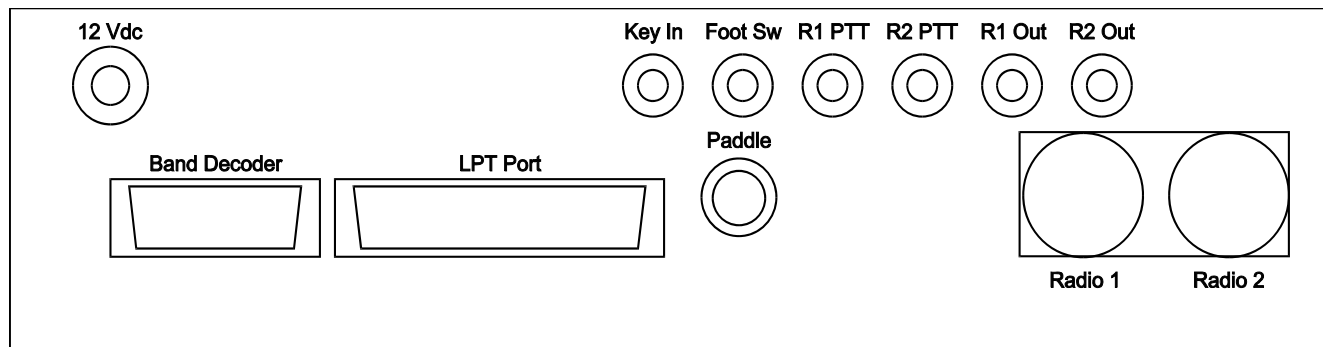

12 Vdc	J12	2.5mm power connection (required)
Key In	J7	Output from CW keyer connects here.
Foot Sw	J8	Connect foot switch here. The PTT line from your mike or DVP™ also connects here with a Y adapter.
R1 PTT	J4	Connects to Radio 1's "Gnd on Tx" line. This is an <i>input</i> to the DXD.
R2 PTT	J5	Connects to Radio 2's "Gnd on TX" line. This is an <i>input</i> to the DXD.
R1 Out	J13	Auxiliary control output. Switches to ground when Radio 1 is selected for TX.
R2 Out	J14	Auxiliary control output. Switches to ground when Radio 2 is selected for TX.
Band Dec.	J11	Connect Top Ten Devices Band Decoder™ here. This would be used if the Band Decoder would normally be connected to the LPT port, but the LPT port is occupied with the cable to the DXD's LPT input connector.
LPT Port	J9	Connect a standard 25 wire straight through computer cable between the computer's LPT port and this connector. The computer provides the following interfaces to the DXD: <ul style="list-style-type: none"> • Radio 1/Radio 2 control line • CW keying signal • "Early PTT" to give the transmitter/amplifier a head start to avoid key clicks. • CW keyer paddle to the LPT (passed through to the "Paddle" connector) • "Stereo" audio control signal from K8CC's NA program. • Transceiver band data from LPT for use with Top Ten Devices Band Decoder for LPT (passed through to the "Band Decoder" connector)
Paddle	J10	Plug in your CW paddle here. Signals are passed through to the LPT port.
Radio 1	J2	Connect main interface cable to Radio 1 here. Carries PTT, CW keying, mike, and receiver audio signals.
Radio 2	J3	Connect main interface cable to Radio 2 here. Carries PTT, CW keying, mike, and receiver audio signals.

See Note on Page 2 of this manual for info on use of the DXD with a computer having only USB ports.



DX Doubler – Two Radio Controller Instruction Manual

Software Compatibility

The DXD is compatible with the following programs for automatic operation of headphone audio and operator interface device control:

CT	N1MM Logger
TRLog	WinTest
NA	
WriteLog	

Please note that certain settings must be made in the program configuration to allow support for the DXD. Users are advised to consult their software program instruction manual for specifics. Due to the evolving nature of software, these settings may change from time to time.

Place the following lines in the TRLog configuration file:

```
RELAY CONTROL PORT = 1 (This enables pin 14 to select R1 or R2)
KEYER RADIO ONE OUTPUT PORT = PARALLEL 1
KEYER RADIO TWO OUTPUT PORT = PARALLEL 1
```

There are slight differences between the way the programs send the control data to the LPT port. CT, TRLog, and WriteLog are the same, while NA is slightly different. To select the appropriate driving software program, you may have to move jumpers on the printed circuit board.

The DXD is shipped configured for operation with CT, TRLog and WriteLog. To reconfigure the DXD for use with NA (or back to CT/TR/WriteLog from NA) follow these steps:

1. Remove the top cover by removing all the screws in the black cover itself only.
2. Locate the programming header P1, which is close to the 25 pin computer connector. Note that this is a standard computer-style programming header, with a single row of ten pins. Adjacent pins are either shorted together or open, depending upon the location of three supplied push-on shorting jumpers.
3. Pin 1 of P1 is closest to the rear of the DXD.
4. Place the jumpers on P1 depending upon the driving software as follows:

Software	Jumper 1	Jumper 2	Jumper 3
CT, TR, WriteLog	1-2	4-5	8-9
NA	2-3	5-6	9-10

5. Replace the top cover of the DXD.

Inputs to and Outputs from the DXD

The following is a complete list of all the inputs and outputs from the DXD:

Table 1 – DXD I/O Connections

Conn.	Type	Description	Pin	Function	Notes
J1	¼" phone, stereo	Phones			Stereo headphones required for full functionality
J2	8 pin DIN	Radio 1	1	CW key line	Location on radio varies, normally back panel
			2	N/C	
			3	PTT line	Location on radio varies, normally mike conn.
			4	RX audio 1	Location on radio varies, norm. headphone jack
			5	Ground	
			6	RX audio 2	Location on radio varies, norm. headphone jack
			7	Mike audio	Normally on front of radio, microphone jack
			8	Mike ground	Normally on front of radio, microphone jack
J3	8 pin DIN	Radio 2	1	CW key line	Location on radio varies, normally back panel
			2	N/C	
			3	PTT line	Location on radio varies, normally mike conn.
			4	RX audio 1	Location on radio varies, norm. headphone jack
			5	Ground	
			6	RX audio 2	Location on radio varies, norm. headphone jack
			7	Mike audio	Normally on front of radio, microphone jack
			8	Mike ground	Normally on front of radio, microphone jack
J4	RCA	Radio 1 PTT line		DXD input from R1 PTT	Radio 1 PTT line. Grounded in Transmit mode.
J5	RCA	Radio 2 PTT line		DXD input from R2 PTT	Radio 2 PTT line. Grounded in Transmit mode.
J6	3.5mm phone	Mike			Heil mike plugs in directly
J7	RCA	Ext. keyer input			Attach external keyer
J8	RCA	Foot switch			Foot switch and/or mike PTT switch
J9	DB-25F	LPT port	1	N/C	
			2	Band Data A	Pass through from LPT to TTD Band Decoder
			3	NA TX 1/ TX 2	High = TX 1, Low = TX 2
			4	NA RX 1/RX 2	High = RX 1, Low = RX 2
			5	NA Stereo RX audio	Same as "Both" on front panel switch
			6	N/C	
			7	Band Data B	Pass through from LPT to TTD Band Decoder
			8	Band Data C	Pass through from LPT to TTD Band Decoder
			9	Band Data D	Pass through from LPT to TTD Band Decoder
			10	N/C	
			11	N/C	
			12	CW paddle – dot	Input for computerized keyer
			13	CW paddle – dash	Input for computerized keyer
			14	CT/TR/WL Rad 1/Rad 2	High = Radio 1, Low = Radio 2
			15	N/C	
			16	"Early" PTT	Goes high early for "click free" CW
			17	CW keying	High state to key the transmitter
18-	Ground				
25	Ground				
J10	¼" phone, stereo	Keyer paddle			Pass through to LPT port for NA
J11	DB-9F	Band Decoder	1	12 Vdc	Power to the decoder
			2	N/C	
			3	Ground	
			4	Band Data A	Pass through from LPT to TTD Band Decoder
			5	Band Data B	Pass through from LPT to TTD Band Decoder
			6	Band Data C	Pass through from LPT to TTD Band Decoder
			7	Band Data D	Pass through from LPT to TTD Band Decoder
			8	Ground	
			9	N/C	
J12	2.5/5.5 mm coaxial	12 Vdc power			12 Vdc regulated power supply connection
J13	RCA	Radio 2 Aux Out			Grounded when Radio 2 selected
J14	RCA	Radio 1 Aux Out			Grounded when Radio 1 selected

See Note on Page 2 of this manual for info on use of the DXD with a computer having only USB ports.



DX Doubler – Two Radio Controller Instruction Manual

Cable Considerations and Requirements

Table 2 – DXD Cables and Connectors

DXD Conn.	From	To	Connector on the Cable	Mouser Cat. No.	Notes												
J1	Phones	DXD Front Panel	¼" stereo phone		Provided with headphones.												
J6	Mike	DXD Front Panel	3.5mm phone	171-1041	Heil mikes plug in directly.												
J2,J3	DXD	Radio 1 and Radio 2	8 pin DIN plug	17HR808	<ul style="list-style-type: none"> ◆ Suggested cable: Mike: RG-174 PTT: RG-174 CW: RG-174 Audio: 2/C #24 shielded ◆ Keep mike ground isolated from other grounds to avoid hum. Connectors at radio end as required by specific radio. Use tie wrap or spiral wrap (Alpha SW, Mouser Cat. No. 602-SW-4-25) to dress cable. ◆ Top Ten Devices sells premade cables for some typical applications. Refer to www.qth.com/topten for details. Also see diagram elsewhere in this manual. 												
J4	Radio 1 PTT	DXD Rear Panel	RCA	17PP058	Connect to radio such that line goes to ground when in TX. Typically amp ctl line.												
J5	Radio 2 PTT				Mates with connector on external keyer.												
J7	Keyer				Typically connects to FS directly. Use a Y adapter to parallel connect the mike's PTT switch.												
J8	Foot Switch				Mates with whatever external devices are being controlled.												
J13	Radio 2 Out																
J14	Radio 1 Out																
J9	LPT port	DXD Rear Panel	DB-25M		Standard 25 wire computer cable, male on DXD end, as required on computer end to mate with LPT port.												
J10	Paddle	DXD Rear Panel	¼" stereo phone	17PP054	Any 3/C cable will suffice.												
J11	DXD Rr Pnl	Top Ten Bnd Decdr	DB-9M		<p>This cable is required only if the computer is being used for automatic antenna control with the Top Ten Devices Band Decoder for LPT Ports. The decoder would normally be connected directly to the LPT port. When the DXD is connected to the LPT port with a 25 wire cable (See J9 above), the band data is passed through the DXD and present on DXD output connector J11. The band decoder input requires a DB-25M wired as follows:</p> <table style="margin-left: 40px; border: none;"> <tr><td>Band Data A</td><td>Pin 2</td></tr> <tr><td>Band Data B</td><td>Pin 7</td></tr> <tr><td>Band Data C</td><td>Pin 8</td></tr> <tr><td>Band Data D</td><td>Pin 9</td></tr> <tr><td>12 Vdc</td><td>Pin 12</td></tr> <tr><td>Ground</td><td>Pin 25</td></tr> </table> <p>This cable can be made with DB-9M and DB-25M connectors and hoods available readily from Radio Shack and other suppliers. Refer to the band decoder instruction manual for further details.</p>	Band Data A	Pin 2	Band Data B	Pin 7	Band Data C	Pin 8	Band Data D	Pin 9	12 Vdc	Pin 12	Ground	Pin 25
Band Data A	Pin 2																
Band Data B	Pin 7																
Band Data C	Pin 8																
Band Data D	Pin 9																
12 Vdc	Pin 12																
Ground	Pin 25																
J12	DC power	DXD Rear Panel	2.5/5.5mm plug	1710-2511	Plug provided with DXD. Recommend RG-174 for cable.												



DX Doubler – Two Radio Controller Instruction Manual

Additional Notes to Table 2:

1. Many RCA-to-RCA cables in various lengths are available from Radio Shack and other suppliers.
2. The most convenient way to connect the DXD to the computer LPT port is to use a standard 25 wire straight through computer cable, available from Radio Shack and many other sources. These cables are available in many different lengths.

Operation of the DXD

Manual vs. Automatic

The control of headphone audio and other operator interface devices can either be manual or automatic. In manual, the headphone audio is controlled by front panel toggle switches, as is the selection of which radio receives the mike, footswitch, etc. This allows you to permanently set up your station for two radio operation. In automatic mode, the DXD responds to certain control signals from the logging software via the computer's LPT port. Both manual and automatic operation features are described in more detail below.

Headphone Audio Control

Inputs to the DXD from the Radios

The DXD accepts a total of four audio streams, two from Radio 1 and two from Radio 2. Note that you will need to configure your radios as you see fit and prefer. For example, the two audio streams from an FT-1000MP might be one of the following:

- Case 1 – Both the same, as when listening to VFO A only
- Case 2 – Separate, VFO A in one ear, VFO B in the other ear

In Case 1, the volume of the audio is set by the volume control on the radio. In Case 2, the balance between VFO A and B is manually adjusted by a control on the front of the radio.

Since the DXD accepts both independent streams from each radio, there is no need to reconfigure the cabling for contest vs. general DXing work.

Control Mode Selection

Headphone audio control mode is selected by front panel switch S2, which has three positions:

- Manual
- Auto
- PTT



DX Doubler – Two Radio Controller Instruction Manual

Manual Control

When manual control is selected by S2, front panel toggle switch S1 (Radio 1/Both/Radio 2) allows full manual control of what you are hearing. Manual control would be desired if the controlling computer program is not currently running, which is likely during everyday operation. Also, Manual Mode provides access to the “Both” setting, which is useful for Search and Pounce operation on the second radio, while CQing on the main radio.

Remembering that the DXD accepts four audio inputs, the following table describes what your left and right ears are hearing for each of the three positions on the control switch:

Switch Position	Left Headphone	Right Headphone
Radio 1	Radio 1 – Audio 1	Radio 1 – Audio 2
Both	Radio 1 – Audio 1	Radio 2 – Audio 2
Radio 2	Radio 2 – Audio 1	Radio 2 – Audio 2

Again, keep in mind that Audio 1 and Audio 2 from each radio can be the same, and in many operating conditions, will be the same. However, the DXD provides the flexibility to exploit the second receiver and its independent audio stream that is available in many of the modern transceivers.

Automatic Control

On mode switch S2, there are two different settings which provide automatic receiver audio switching features:

- Auto
- PTT

In Auto mode, the headphones are connected to the radio selected by the logging software.

In PTT mode, the DXD monitors the transmit status of the two radios. When neither transmitter is on the air, the headphone audio is in *Both* mode, i.e. Radio 1 in the left ear and Radio 2 in the right ear. As soon as one of the radios goes into transmit mode, the headphones are connected to the radio that is not transmitting, allowing for aggressive Search & Pounce operation on one band while CQing on another.

Although most SO2R operators will have a computer handling the logging and transceiver control chores, please note that the PTT mode works equally well with the Transmitter Selection Control in Manual. For example, if you are CQing on Radio 1, while tuning on Radio 2, and find a station you wish to call on Radio 2, all that is needed is to flip S3 from Radio 1 to Radio 2, and then you are ready to call the desired station. On the other hand, in Transmitter Select Auto Mode, a computer keyboard



DX Doubler – Two Radio Controller Instruction Manual

keystroke or key combination is required to toggle from Radio 1 to Radio 2, and then back after the QSO is made. See below for more on Transmitter Selection Control.

The following table summarizes headphone response under both types of automatic control.

Switch Position		Left Headphone	Right Headphone
Auto		Software selected radio – Audio 1	Software selected radio – Audio 2
PTT	While listening	Radio 1 – Audio 1	Radio 2 – Audio 1
	While transmitting	Non-transmitting radio – Audio 1	Non-transmitting radio – Audio 1

NA's Stereo Mode

If the computer program in use is NA, and Auto mode is selected, pressing Ctrl-S on the computer keyboard will connect the left headphone to the Radio 1 and the right headphone to Radio 2. This headphone mode is identical to that achieved in Manual Mode and selecting Both on S1. This feature is not available in PTT nor Manual mode.

Audio Mix

This feature is manually enabled by the front panel toggle switch S5. If enabled, the operator can vary the amount of mixing of audio between the left and right headphone speakers. This feature would only be useful where left and right audio signals are different, as in when “Both” is selected in Manual mode, or “PTT” is selected in automatic mode.

Transmitter Selection Control

Transmitter selection is controlled by directing a single set of signals from the DXD to one or the other of the two transceivers. These signals are:

- Microphone audio
- CW key line
- PTT line

Control Mode Selection

Transmitter control mode is selected by front panel switch S4, which has two positions:

- Manual
- Auto



DX Doubler – Two Radio Controller Instruction Manual

Manual Control

When manual control is selected by S4, front panel toggle switch S3 (Radio 1/Radio 2) allows manual selection of which transceiver is selected as the active transmitter. Manual control would be desired if the controlling computer program is not currently running, which is likely during everyday operation. Also, there may be times during a contest situation when automatic operation needs to be overridden.

Automatic Control

If a controlling computer program is running, and automatic control is selected by S4, the active transmitter is selected by the computer program. The active transmitter can be determined either by looking at the red LEDs on the DXD (only one will be lit) or by viewing the computer program CRT display. Please refer to the instructions for the computer program in use to determine how your program provides this visual indication of the selected radio.

Typical Application

The following diagram shows a typical application of the DXD. The radios are assumed to be two Yaesu FT-1000MPs, where the CW key input is available on the front panel of the radio. The computer program running is assumed to be CT, and a DVP voice memory keyer is being used. This diagram is illustrative of the connections that can be used. Many other variations are possible.

For example, if the computer is running N1MM or other Windows software that supports sound card voice memory keyers, the microphone would be connected to the sound card, and the speaker output from the sound card would be routed to the DXD's mic input connector. Check your software's documentation on correct hookup.

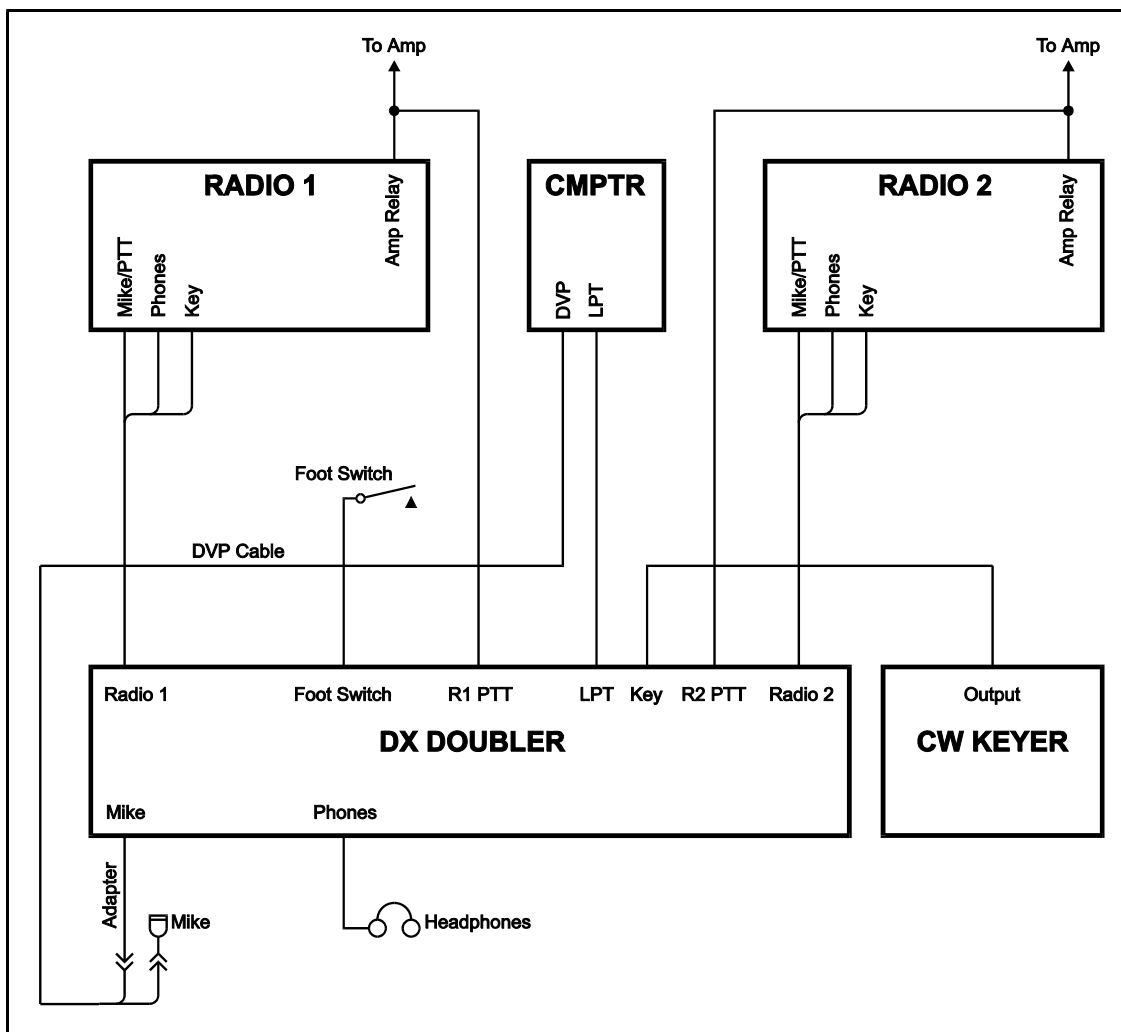

Notes:

1. Refer to Tables 1 and 2 for details of cable pin outs and construction.
2. Use of the DVP cable requires use of an adapter plug. If a new cable is made for the DVP, 1/4" male and female connectors can be used, and the adapter avoided.

Schematic Diagram

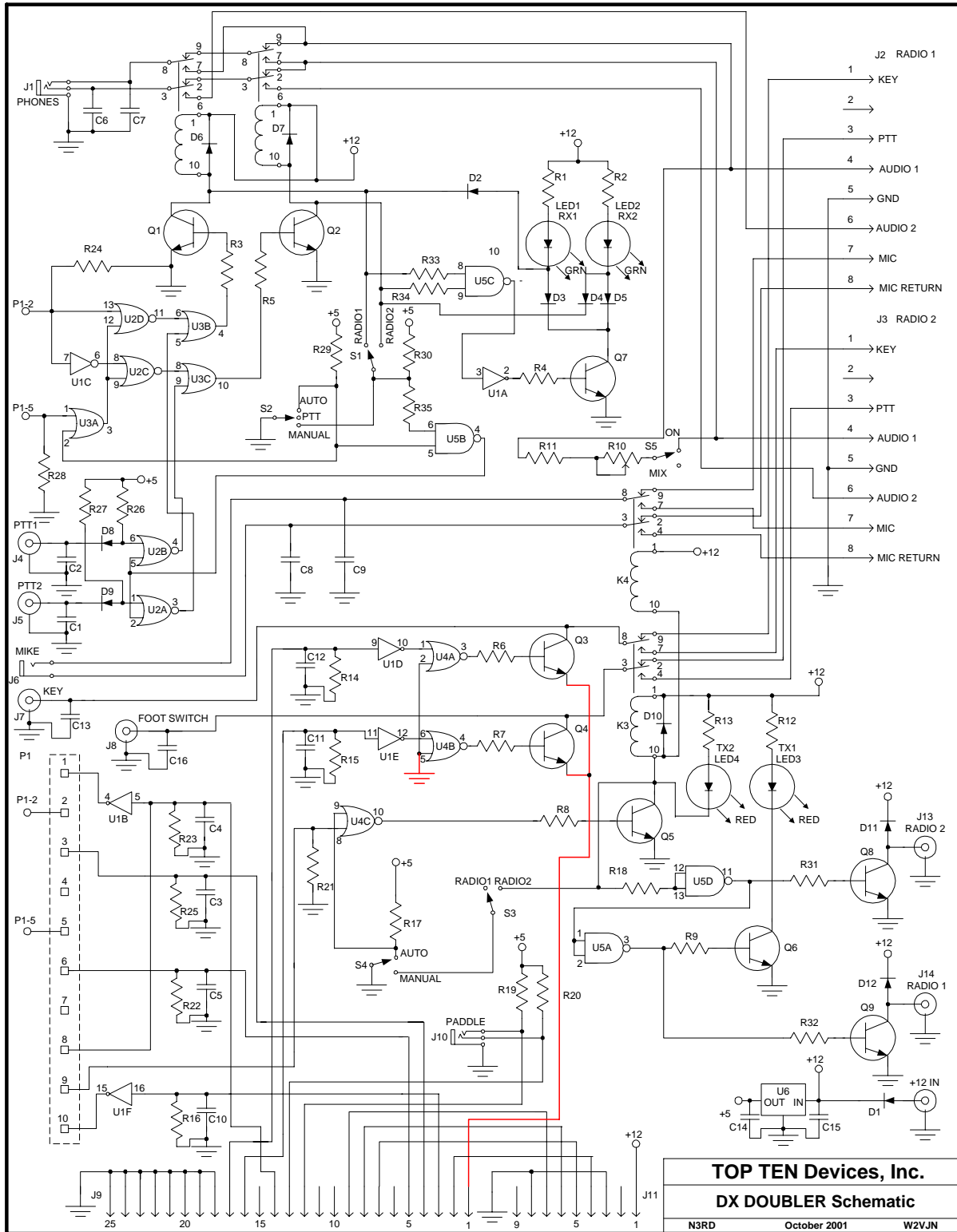

Parts List

Part	Description
C1-13,16	0.001, 50 V ceramic disk
C14	0.1uF, 50V ceramic
C15	22uF, 35V electrolytic
D1	1N4001
D2-14	1N914B
K1,2,3,4	DPDT Relay, 12 Vdc
LED1,2	Green LED
LED3,4	Red LED
Q1-9	2N4401, NPN transistor
R1,2,12,13	1.0K, ¼ W
R3,4,5,6,7,8,9,31,32	3.0K, ¼ W
R10	1000 Ohm potentiometer
R11	20 ohms, ¼ W
R14-20,22,23,25-27,29,30	10K, ¼ W
R21,24,28	470K, ¼ W
R33-37	100K, ¼ W
U1	4049, hex buffer/inverter
U2,4	4001, quad 2-input NOR gate
U3	4071, quad 2-input OR gate
U5	4011, quad 2-input NAND gate
U6	78L05, 5V regulator



DX Doubler – Two Radio Controller Instruction Manual

Cable Wiring Diagrams

For wiring diagrams of DXD-to-radio interface cables, please refer to Appendix A.

For wiring diagrams of DVP™ cable adapters, please refer to Appendix B.

Limited Warrantee

Top Ten Devices warrants this unit to be free from defects in parts and workmanship for a period of one year. The unit will be either repaired or replaced, at our discretion. The only cost will be the cost of return shipping. If repairs are required during the warrantee period for other than manufacturing or parts defects, an estimate of the repair cost will be provided prior to repair.

Top Ten Devices is not responsible for any consequential damages to other equipment or personnel injury as a result of using this product, or any of the suggested uses.

If the terms of the above Warrantee and Limitation of Liability are not acceptable, please return the unit to Top Ten Devices for a full refund.

Specifications

Power Supply Voltage	+12 to +15 volts dc
Current required	30 mA
Switched outputs for Radio 1 and Radio 2	200 mA at 50 volts dc



DX Doubler – Two Radio Controller Instruction Manual

APPENDIX A

DXD-to-Transceiver Interface Cables Wiring Diagrams

DX Doubler – Two Radio Controller Instruction Manual

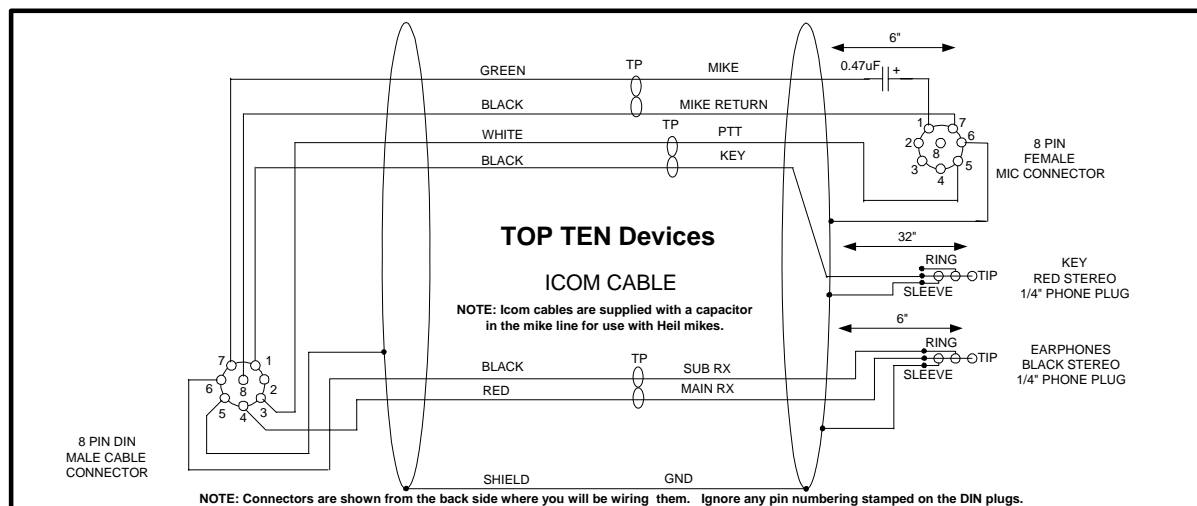
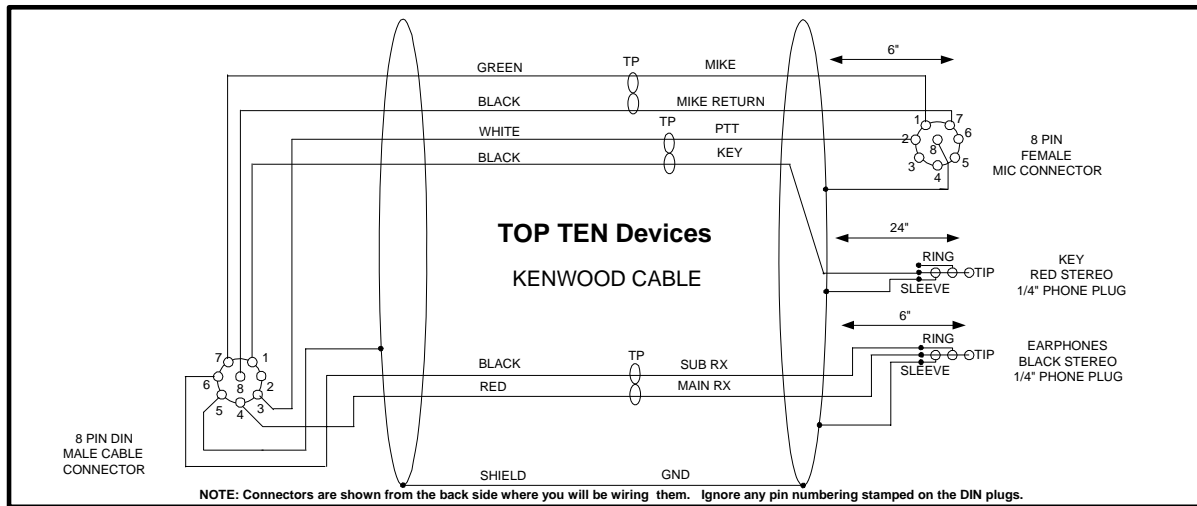
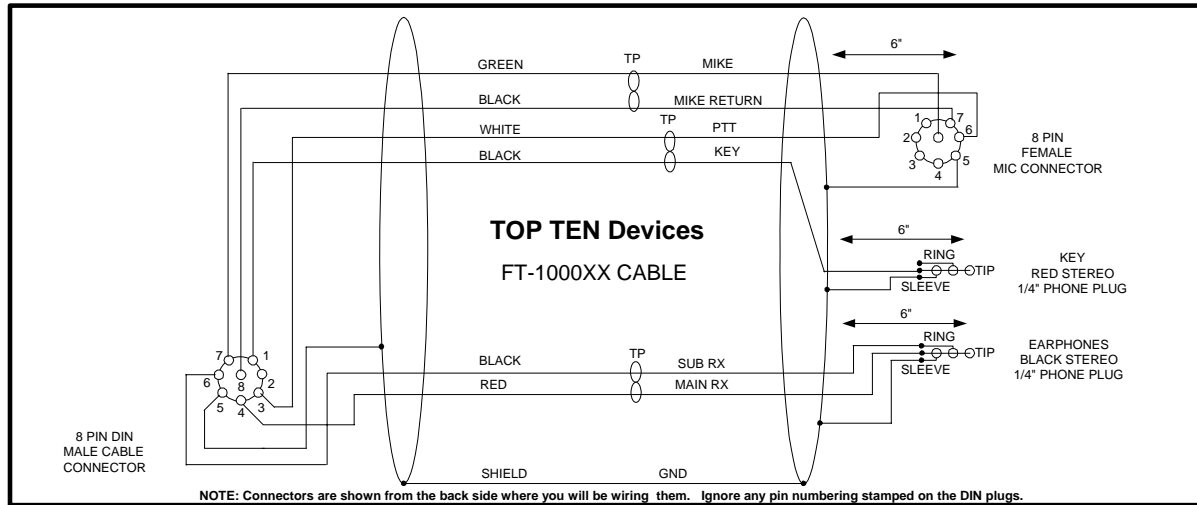

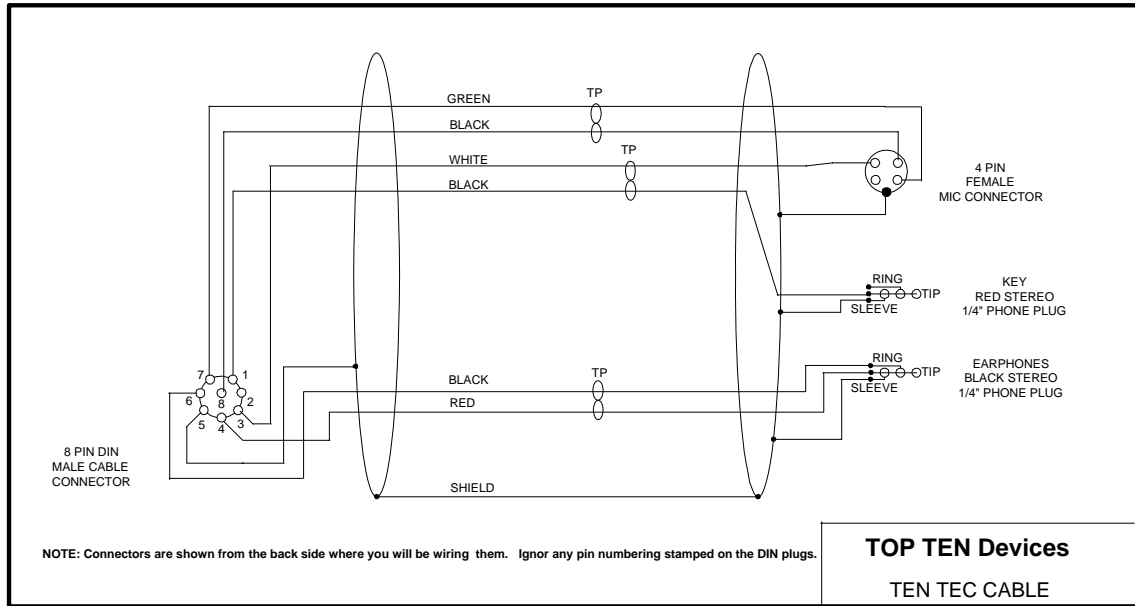

Note: The stranded drain wire at the 4-pin microphone plug is folded back and extended out the back of the connector. When the cable clamp is assembled, the drain wire is wrapped around one of the two screws on the clamp before tightening, thus providing a solid connection of the drain to the body of the plug.

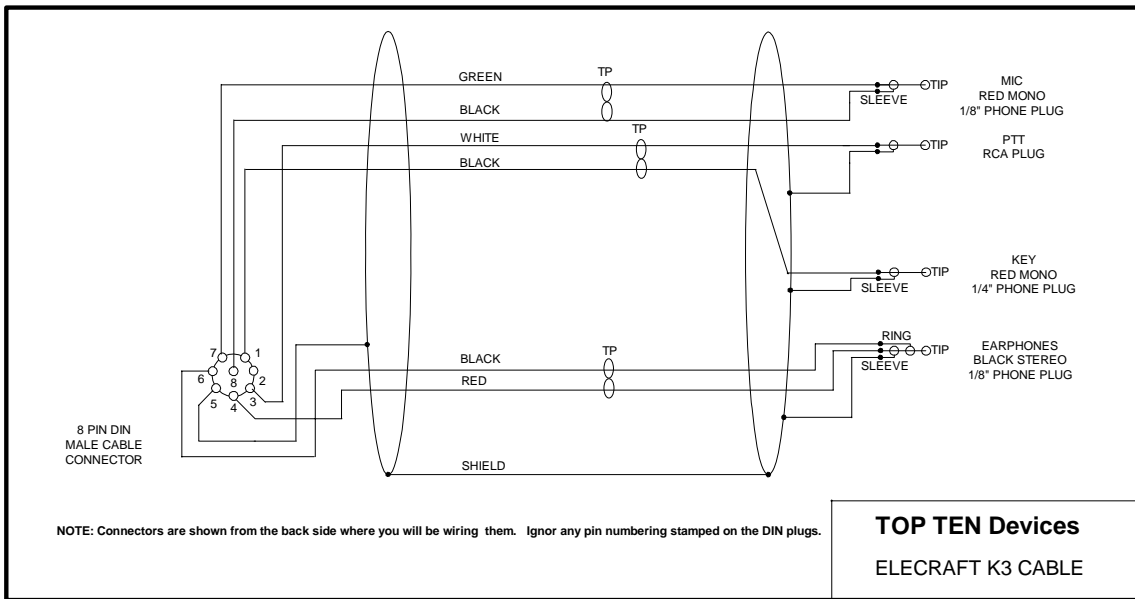



DX Doubler – Two Radio Controller Instruction Manual

APPENDIX B

DVP Cable Adapters Wiring Diagrams

DX Doubler – Two Radio Controller Instruction Manual

DVP Adapter for Use with Yaesu Radios

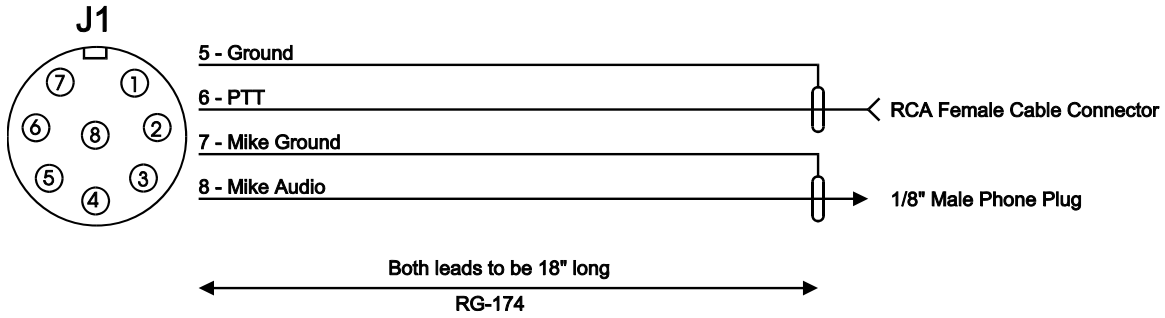

DVP Adapter for Use with Icom Radios

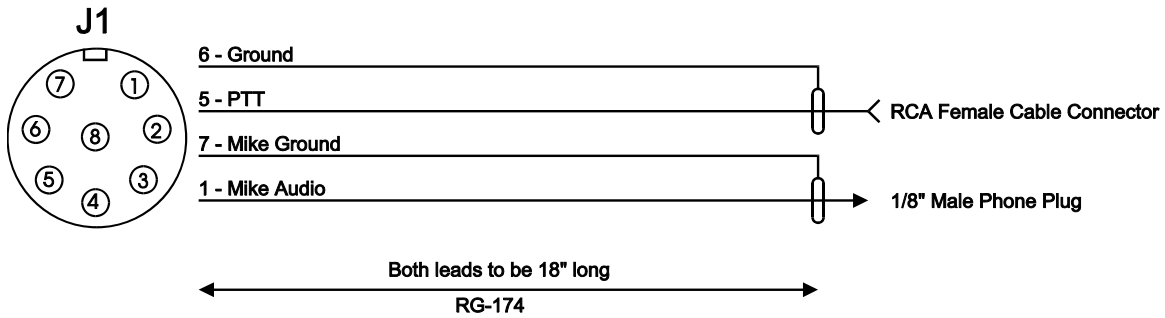

DVP Adapter for Use with Kenwood Radios

